

CATALOG #	DESCRIPTION	CHARGER CATALOG NO.
VCBP63	ANDERSON 4 POINT DIELESS CRIMPING TOOL	PATCHGRLI

*** BILL OF MATERIAL ***

PT NO.	CATALOG NO.	QTY	DESCRIPTION
1	VCBP63	1	ANDERSON 4 POINT DIELESS CRIMPING TOOL
2	BAT18VLI	2	BATTERY, LITHIUM ION 18V
3	PATCHGRLI	1	CHARGER, BATTERY LITHIUM ION
4	ANDCASELI	1	CASE, TOOL ANDERSON LITHIUM-ION - BLACK
5	PT208620	1	LANYARD
6	BATCHGRLIOMI	1	BATTERY CHARGER SAFETY OPERATING MAINTENANCE & INSTRUCTIONS
7	VCBP63OMI	1	SOMI, ANDERSON VCBP63 & VCBP6FT

BATTERY ACTUATED TOOL - HYDRAULIC SELF CONTAINED - 6 TON OUTPUT FORCE

SPECIFICATIONS

CRIMP FORCE: 6 TONS (5.4 METRIC TONS)
TOOL WEIGHT: 13.2 LBS (5.9 kg)
LENGTH: 15.75 (40.00 cm)
WIDTH: 3.50 (8.89 cm)
HEIGHT: 13.50 (34.29 cm)
OPERATING VOLTAGE: 18V-DC
RECHARGE TIME: 30 MINUTES

FEATURES AND BENEFITS

- REFINED HYDRAULIC SYSTEM FOR SUPERIOR PERFORMANCE, SPEED AND RELIABILITY.
- FIELD PROVEN ELECTRONICS FOR ULTIMATE RELIABILITY IN THE HARSHTEST ENVIRONMENTS.
- OVERMOLDED HANDLE FOR COMFORT AND IMPROVED GRIP; ALLOWS FOR ONE-HANDED OPERATION FOR ADVANCE, RETRACT AND HOLD.
- 18 VOLT LITHIUM-ION BATTERIES PROVIDE 2.5 TIMES MORE CHARGE / DISCHARGE CYCLES THAN TRADITIONAL 14 VOLT Ni-Cd BATTERIES AND PROVIDE 430% MORE LIFETIME WORK.
- 30 MINUTE CHARGER CONTROLS CURRENT, VOLTAGE AND TEMPERATURE TO MAXIMIZE BATTERY LIFE. FORCED AIR COOLING. FAN COOLS THE BATTERY BY FORCING AIR THROUGH THE BATTERY'S BUILT-IN AIR VENTS.
- STATE OF THE ART "C" STYLE CRIMPING HEAD DESIGN, 360 DEGREE ROTATION LETS THE USER GET INTO TIGHT AREAS EASIER.
- DIELESS SYSTEM ELIMINATES THE NEED TO PURCHASE AND MAINTAIN DIES.
- DIELESS SYSTEM ALLOWS APPROVED CONNECTORS AND SPLICES TO BECOME RANGE TAKING.
- ERGONOMICALLY BALANCED TOOL DESIGN EASES OPERATION AND HELPS LESSEN FATIGUE.
- DURABLE HIGH IMPACT PLASTIC CARRYING CASE PROVIDES SUPERIOR PROTECTION AND STORES ALL ACCESSORIES.

NOTES:

- 1 LANYARD IS STORED IN COMPARTMENT UNDER THE LID.

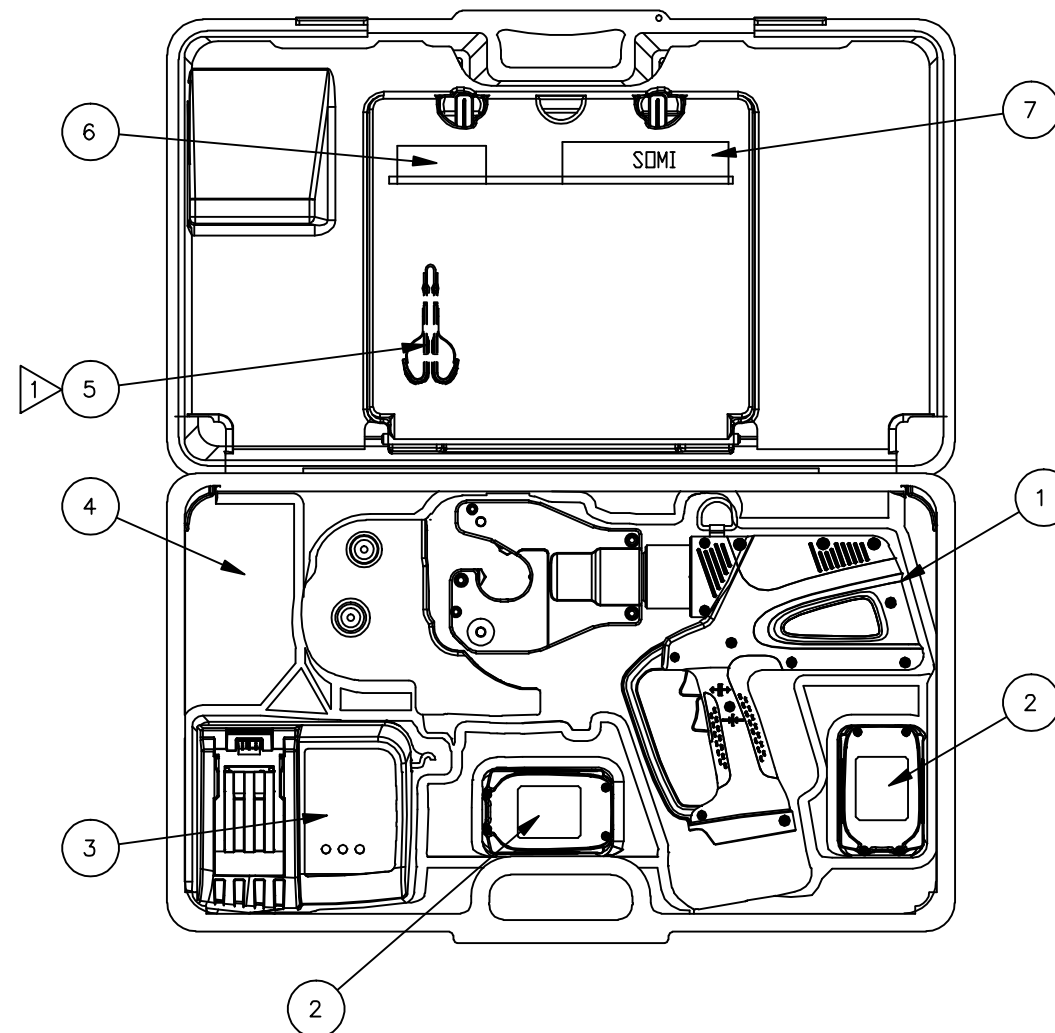
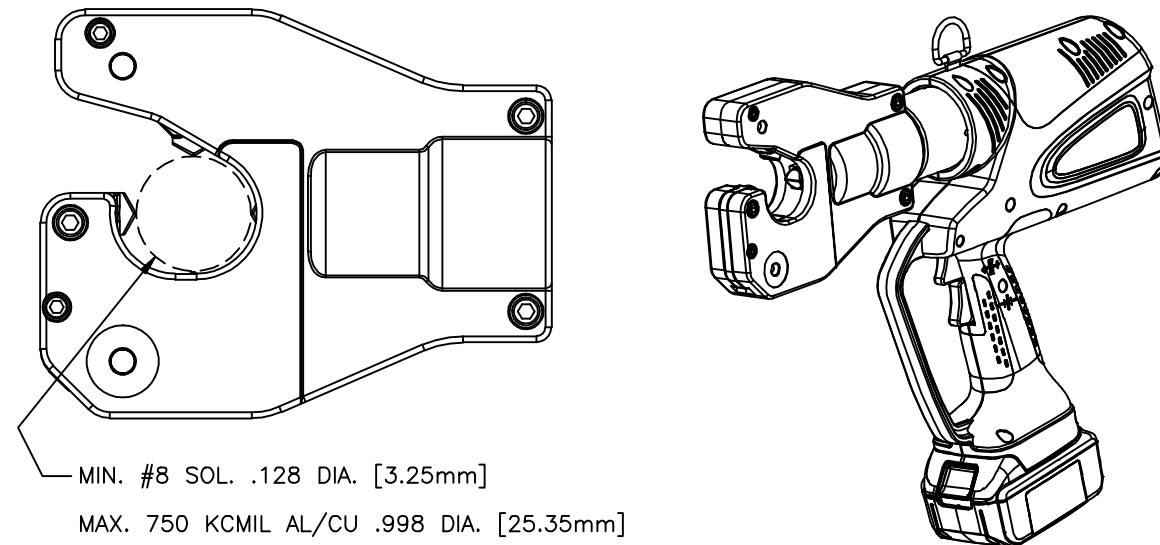

57890	10/3/14	JES	JES	ANDERSON TOLERANCE CHART	HUBBELL POWER SYSTEMS			
EC #	DATE	CHG BY	RESP ENG		TITLE VERSA-CRIMP BATTERY TOOL			
DESC OF DWG UPDATED BOM TO INCLUDE VCBP63 TOOL				CONFIDENTIAL: THIS DRAWING AND ITS CONTENTS ARE CONFIDENTIAL AND THE EXCLUSIVE PROPERTY OF HUBBELL POWER SYSTEMS. NO PUBLICATION, DISTRIBUTION OR COPIES MAY BE MADE WITHOUT THE WRITTEN CONSENT OF HUBBELL POWER SYSTEMS. HUBBELL POWER SYSTEMS UNPUBLISHED ALL RIGHTS RESERVED UNDER THE COPYRIGHT LAWS.	SIZE	DWG NO.	CAT / PART / ASSY NO.	REV
REASON (S) FOR CHANGE: -- DISPOSITION OF MAT'L: --					C	CC-19905	VCBP63	01
				DO NOT SCALE THIS DRAWING	DRN BY BAF	DATE 7/11/11	SHEET 1 OF 1	